

ELEVATION VIEW

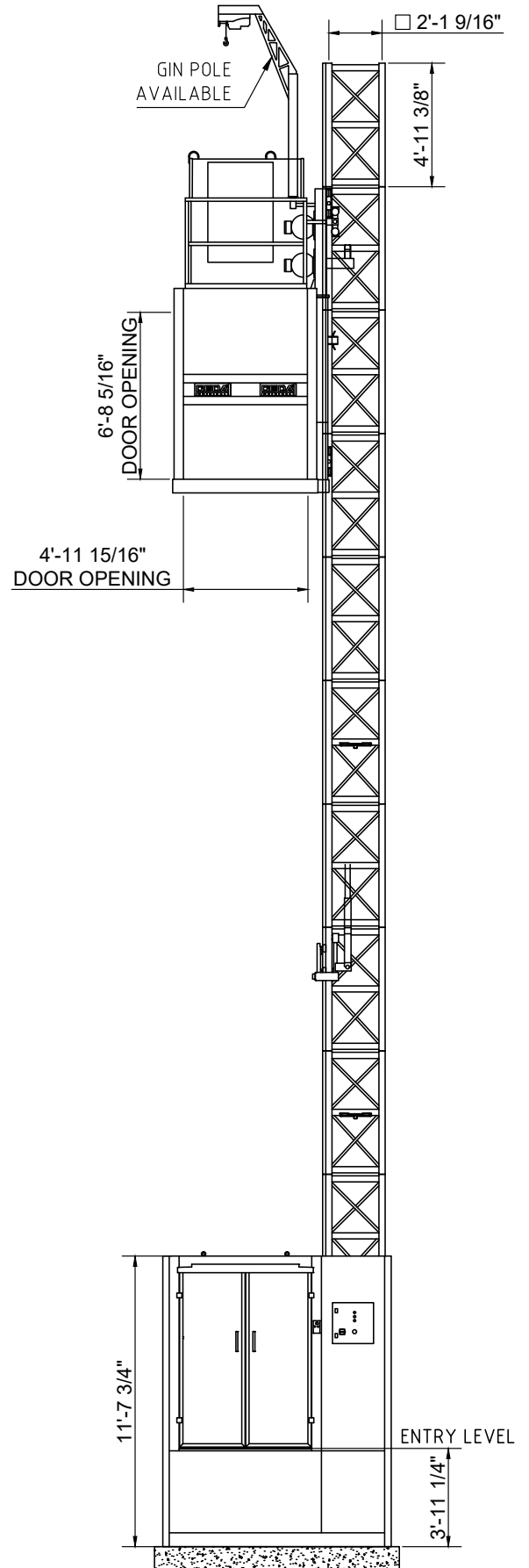

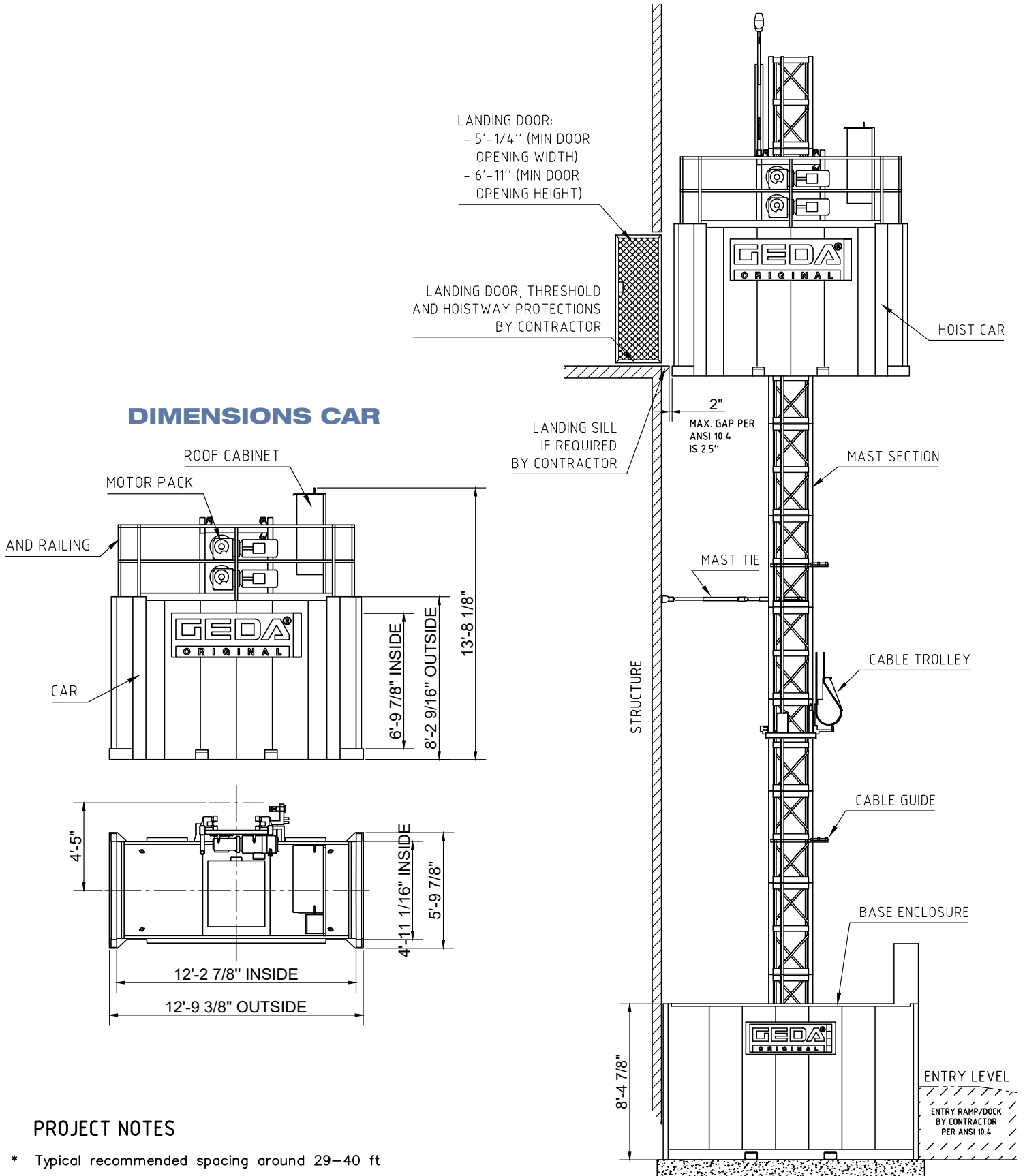

PROJECT NOTES

* Typical recommended spacing around 29–40 ft

** Placing of landings should be avoided at max. free top due to the deflection of the mast.

TIE-IN DETAILS - SLAB MOUNTED

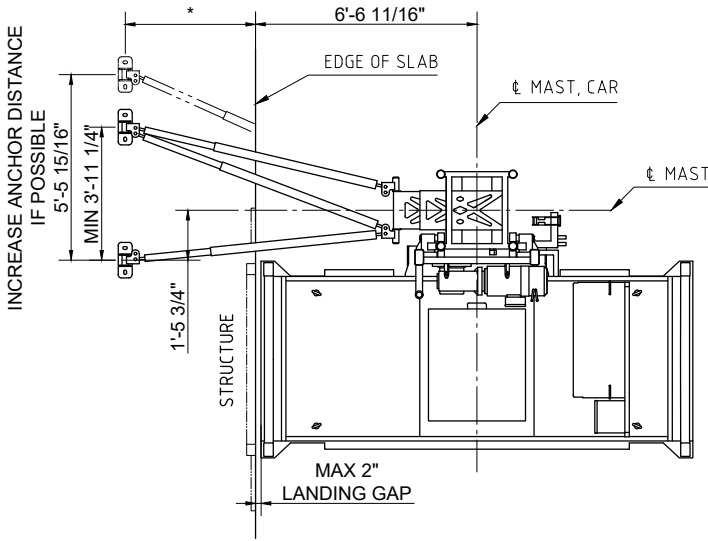

ELEVATION VIEW

TIE-IN DETAILS - SLAB MOUNTED WITH LANDING SILL

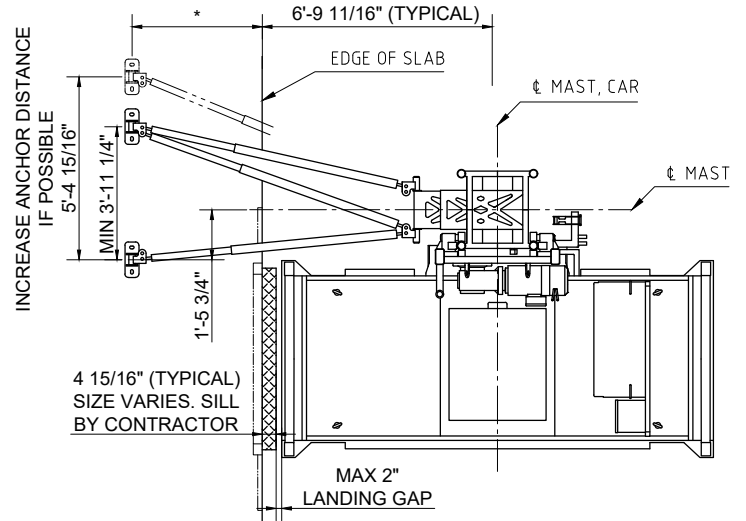

INCLINATION DETAILS

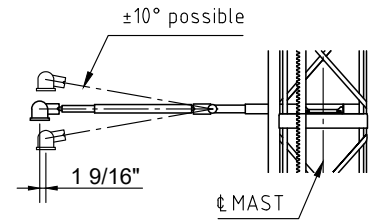
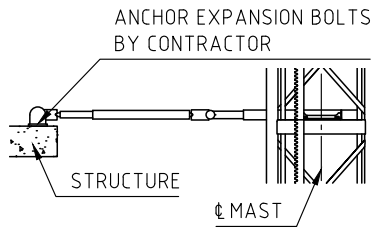

TIE-IN PLATE

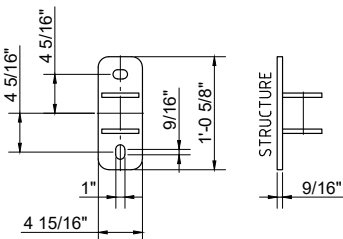

ATTACHMENT POINTS

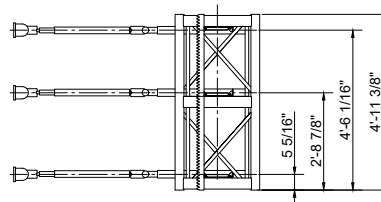

ADDITIONAL TIE-IN PLATES TO DISTRIBUTE THE ANCHOR LOADS REQUIRED (DEPENDING ON SITE CONDITIONS)

TIE-IN LOADS

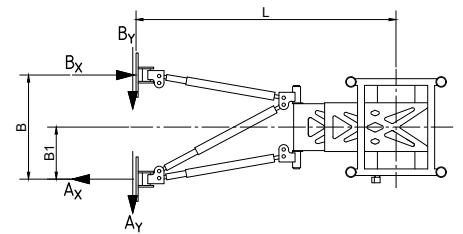

PLEASE SEE GEDA INSTALLATION MANUAL FOR TIE-IN LOADS

ALTERNATE MAST TIES OR ANCHORING DISTANCES AVAILABLE. CONTACT GEDA FOR INFORMATION.

TIE-IN DETAILS - WALL MOUNTED

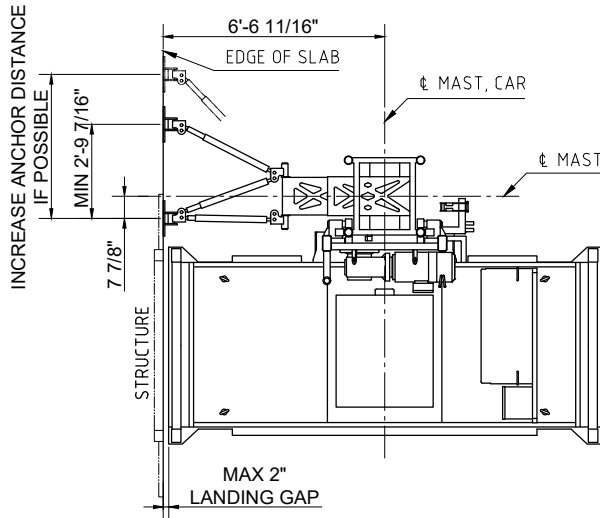

ELEVATION VIEW

TIE-IN DETAILS - WALL MOUNTED WITH LANDING SILL

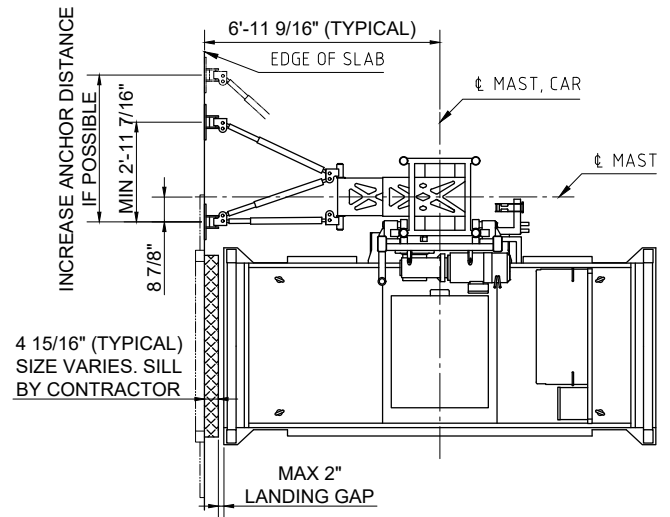

INCLINATION DETAILS

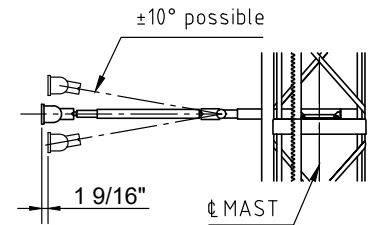
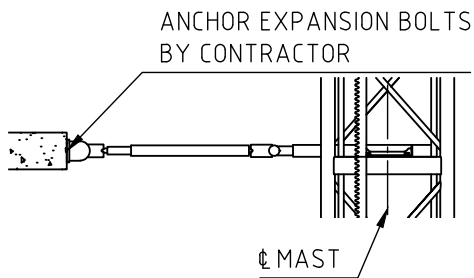

PROJECT NOTES

- * Distance to slab depending on site conditions (e. g. quality of concrete, wind loads, typ of ancore, ...)

PLAN VIEW BASE ENCLOSURE

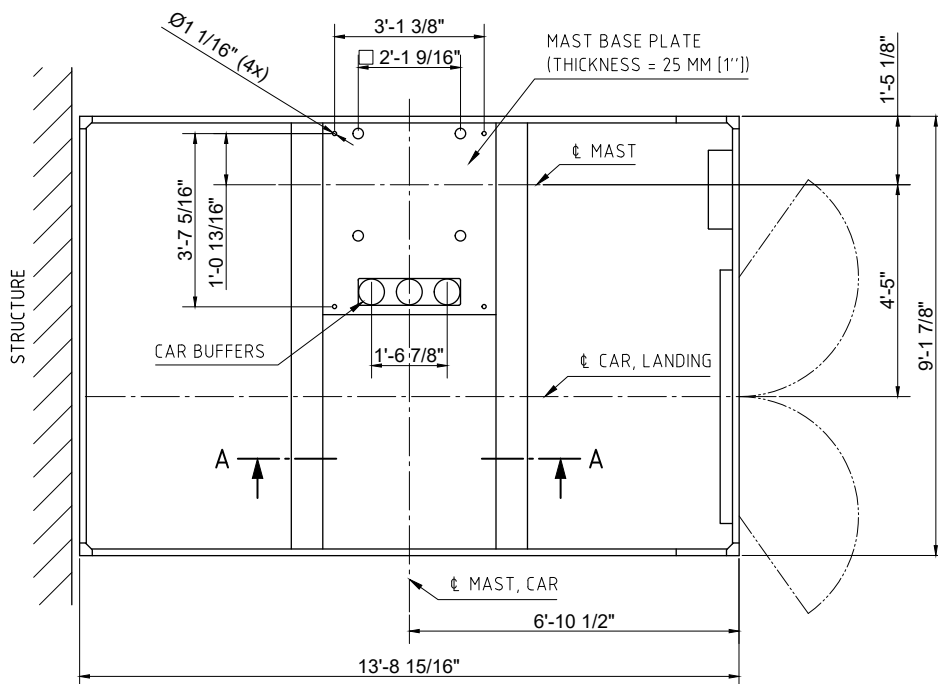

MAST BASE

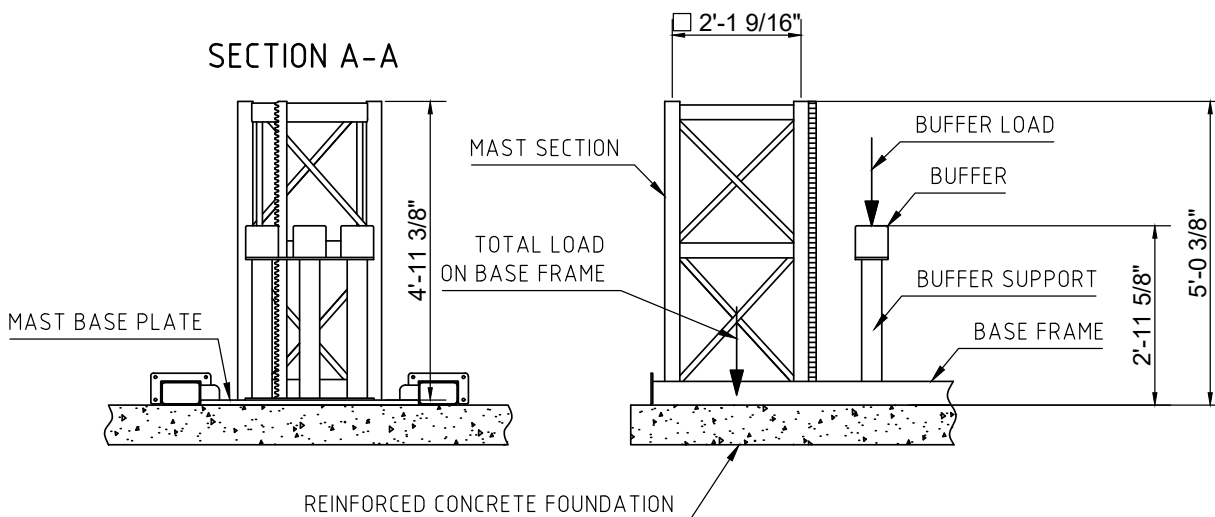

PLEASE SEE GEDA INSTALLATION MANUAL FOR TOTAL LOAD ON BASE FRAME AND BUFFER LOAD.

FOUNDATION PLAN VIEW

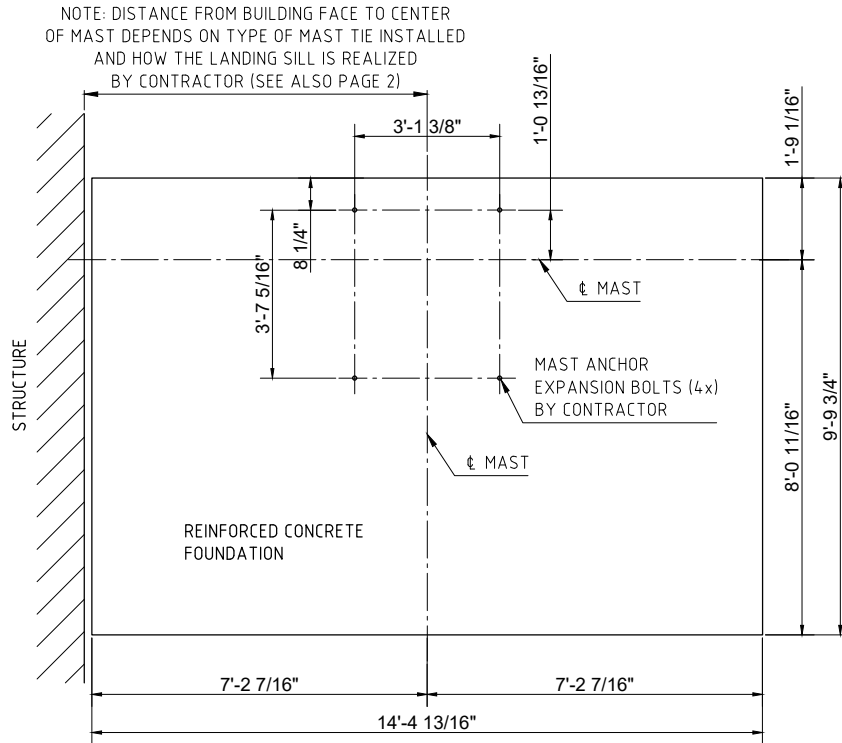

FOUNDATION SIDE VIEW

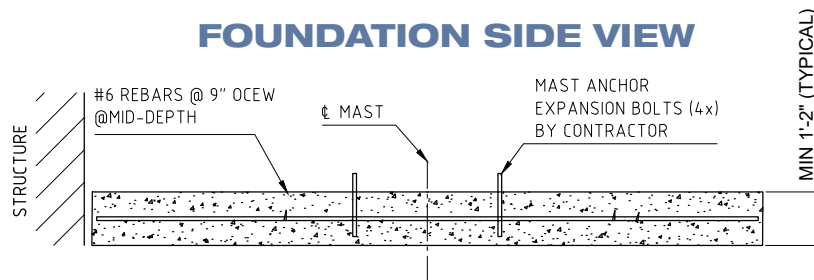

- FOUNDATION NOTES:
1. FOUNDATION BASED ON 310' MAST HEIGHT.
 2. FOR MAST HEIGHTS ABOVE 310', PLEASE CONTACT OUR ENGINEERING DEPARTMENT FOR DESIGN SPECIFICATIONS.
 3. FOUNDATION DESIGNED FOR MINIMUM SOIL BEARING OF 1250 PSF.
 4. CONSTRUCTION SHALL BE IN ACCORDANCE WITH THE GOVERNING INTERNATIONAL BUILDING CODE.
 5. STEEL REINFORCEMENT SHALL CONFORM TO ASTM A615 GRAD 60.

SPECIFICATIONS

MACHINE TECHNICAL DATA SPECS

MACHINE TYPE:	GEDA PH6000
CONFIGURATION:	SINGLE, LEFT CAR
CAPACITY:	6000 POUNDS
LIFTING HEIGHT:	VARIES (MAX 400m)
RATED SPEED:	196 ft/min.
NUMBER OF MOTORS:	2x19 kW (105 Hz)
MOTOR PACK TYPE:	VFC

COMPONENTS WEIGHT

BASE ENCLOSURE:	3100 LBS
CAR:	3980 LBS
MOTORPACK:	1800 LBS
ROOF CABINET:	575 LBS
MAST SECTION SINGLE:	343 LBS
MAST TIE:	230 LBS
CABLE GUIDE	12.5 LBS
CABLE TROLLEY:	165 LBS

POWER SUPPLY REQUIREMENTS (PER CAR)

VOLTAGE:	480 V, 3 PHASE	FREQUENCY:	60 HZ
MAINS FUSES:	100 A	POWER CONSUMPTION	88 kVA



Machinery Directive 2006/42/EG
DIN EN ISO 9001:2008

